

The SOLIDWEDGE™ is a breakthrough technology that allows conduction cooled modules to operate at higher thermal loads in higher temperature environments.

OPTIMIZED FOR VITA 48.2 AND CPCI



US PATENT
8,456,846

POSITIVE RETRACTION

Adjacent wedge segments are connected to prevent a stuck wedge lock. Turning the drive screw counterclockwise retracts the threaded drive wedge, pulling each of the connected segments down to their relaxed position.

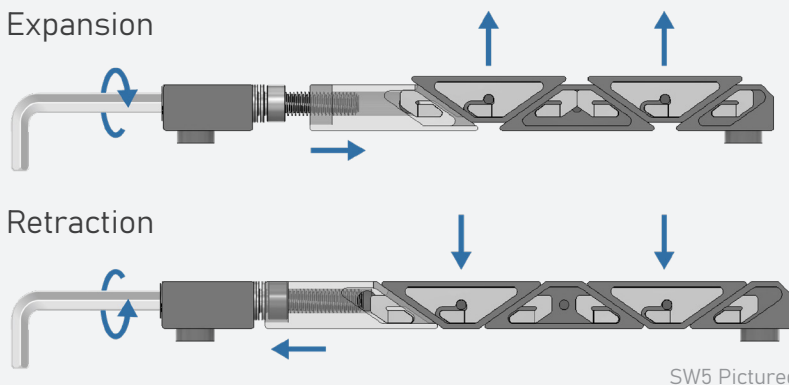

THERMAL RESISTANCE

0.07 °C/W Resistance per Card Edge

FEATURES

- 2300 lb Clamping Force
- Mass: 28 g
- Helicoil Insert
- Belleville Spring Washers
- #10 Drive Screw
- Zero Insertion Force
- Low Profile Design
- Self-Retracting Segments
- Superior Plating Endurance
- Optimized for Vita Specifications
- Models Available for Download
- Torque to 15-30 in-lbs

MATERIALS

Active Wedge Segments: 6061-T6511

Front Mounting Block: 6061-T6511

Screws, Nuts, Washers:
300 Series Stainless Steel
(passivated per AMS - 2700)

Helicoil Wire Insert: Nitronic 60

3D MODEL:

<https://a360.co/49wYA8g>

The SOLIDWEDGE™ design provides three times the thermal contact area of conventional wedge locks. The design also features a larger screw size, which creates higher contact forces between the heat frame and cold wall surfaces, significantly improving thermal performance.





The interconnected links of the SOLIDWEDGE™ feature positive retraction of all segments without the use of springs or other mechanisms.

PART NUMBER BUILDER

Required

Additional Specifications

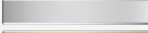
SW7	455	375	375	XXX	XX	YY		
Wedge:	Spacing: 4.55" MOUNTING HOLE SPACING	Height: 0.375"	Width: 0.375"	Hex:	Finish:	1 [NL] - NYLOK LOCK PATCH	2	3
SW - SOLIDWEDGE 7 - ACTIVE SEGMENTS		5/32" HEX KEY - [532] M4 HEX KEY - [M4]						

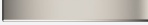
	BLACK ANODIZE PER MIL-A-8625, TYPE II, CLASS 2	[BA]
	HARD BLACK ANODIZE PER MIL-A-8625, TYPE III, CLASS 2	[BH]
	CHEMICAL FILM PER MIL-C-5541, CLASS 1A, CLEAR	[CC]
	CHEMICAL FILM PER MIL-C-5541, CLASS 1A, GOLD, NON-ROHS	[CG]
	ELECTROLESS NICKEL PER MIL-C-26074, CLASS 4, GRADE B, BRIGHT	[EN]

RECOMMENDED PART NUMBER: SW7-455-375-375-532-BA

MOUNTING DETAILS

