

The SOLIDWEDGE™ is a breakthrough technology that allows conduction cooled modules to operate at higher thermal loads in higher temperature environments.

OPTIMIZED FOR VITA 48.2 AND CPCI



**US PATENT
8,456,846**

DOUBLE THREADED DRIVE SCREW

Double end threaded drive screw reduces the number of turns on the drive screw by one half. The opposing threads reduce loosening during shock and vibration and create a more evenly distributed stress concentration on each thread. Adjacent wedge segments are connected to prevent a stuck wedge lock.

Expansion



Retraction



US PATENT 12,610,490

SWD5 Pictured

THERMAL RESISTANCE

0.12 °C/W Resistance per Card Edge

FEATURES

- 1300 lb Clamping Force at 15 in-lbs
- Mass: 19 g
- Helicoil Insert
- Zero Insertion Force
- Low Profile Design for Thicker Heat Frame
- Self-Retracting Segments
- Superior Plating Endurance
- Optimized for Vita Specifications
- Models Available for Download Torque to 8-15 in-lbs

SELF LOCKING THREADS

The EMUGE Self-Lock™ locking feature is integrated into the internal profile and works without any additional mechanical or chemical locking devices, therefore temperature variations do not noticeably affect it. This eliminates the need for secondary locking features and reduces FOD. <https://info.emuge.com/self-lock>

3D MODEL:

<https://a360.co/4pyJx4v>

The SOLIDWEDGE™ design provides three times the thermal contact area of conventional wedge locks. The design also features a larger screw size, which creates higher contact forces between the heat frame and cold wall surfaces, significantly improving thermal performance.

The interconnected links of the SOLIDWEDGE™ feature positive retraction of all segments without the use of springs or other mechanisms.

PART NUMBER BUILDER

SWD5 - 33 - 200 - 250 - XXX - XX

Wedge:	Spacing:	Height: 0.270"	Width: 0.250"	Hex:	
5.25" MOUNTING HOLE SPACING					
SW - SOLIDWEDGE D - DOUBLE DRIVE B - ACTIVE SEGMENTS			3/32" HEX KEY - [332]		

MATERIALS

Active Wedge Segments:
6061-T6511

Screw and Front Block:
316 Series Stainless Steel
(passivated per AMS - 2700)

Helicoil Wire Insert:
Nitronic 60

	BLACK ANODIZE PER MIL-A-8625, TYPE II, CLASS 2	[BA]
	HARD BLACK ANODIZE PER MIL-A-8625, TYPE III, CLASS 2	[BH]
	ELECTROLESS NICKEL See last page for more plating info	[EN]

RECOMMENDED PART NUMBER: SWD8-525-270-250-332-BA

MOUNTING DETAILS

UNLESS OTHERWISE SPECIFIED
DIMENSIONS ARE IN INCHES.
TOLERANCES:
TWO PLACE DECIMAL: ±.01
THREE PLACE DECIMAL: ±.005

EXPANSION DETAILS

NOMINAL EXPANSION: .025"

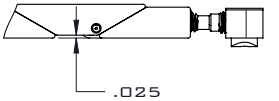

MAXIMUM EXPANSION: .050"

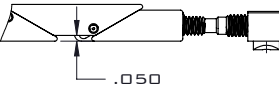
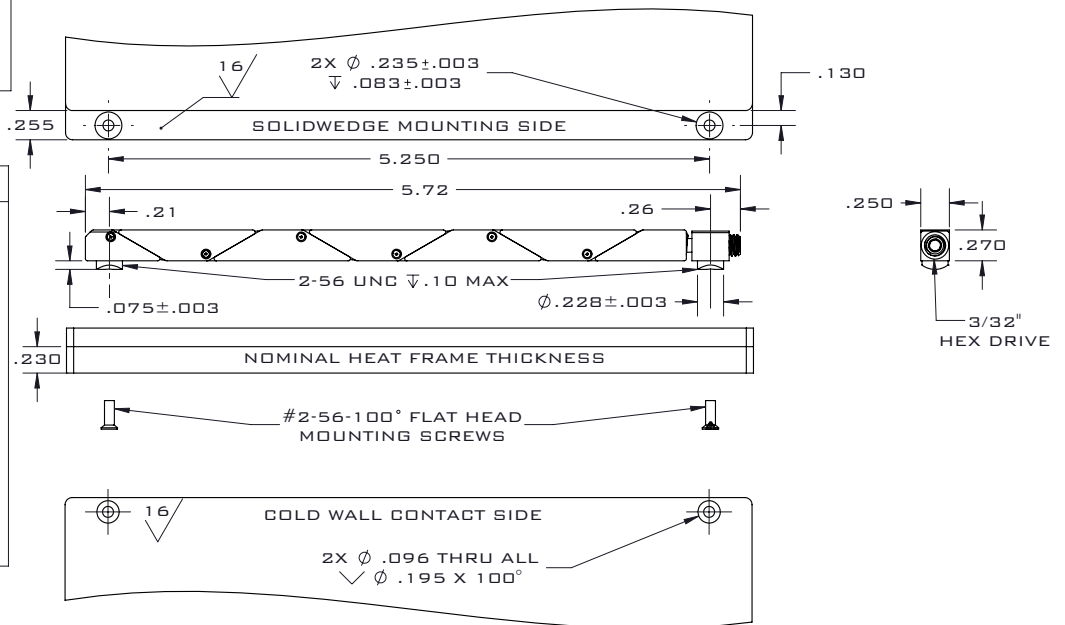
Standard material specs for WaveTherm's SOLIDWEDGE™, injector/ejectors, and OpenCOTS products.

ASSEMBLY HARDWARE



300 SERIES STAINLESS STEEL

Compliance	Specification	Use Case
✓ DFARS	Passivated per	Standard material for screws, nuts, washers, and SOLIDWEDGE™ straps in WaveTherm product assemblies.
✓ RoHS	AMS-2700	
✓ REACH		

ALUMINUM PLATING



BLACK ANODIZED - BA

Compliance	Specification	Properties and Use Case
✓ RoHS	MIL-A-8625	Provides reliable corrosion resistance and durability. Ideal for use in demanding applications requiring high insertion/extraction counts.
✓ REACH	Type II Class 2	



BLACK ANODIZED HARDENED - BH

Compliance	Specification	Properties and Use Case
✓ RoHS	MIL-A-8625	Provides superior corrosion resistance and high durability. Ideal for use in harsh and rugged environments with high insertion/extraction counts.
✓ REACH	Type III Class 2	



ELECTROLESS NICKEL - EN

Compliance	Specification	Properties and Use Case
✓ RoHS	MIL-C-26074	Provides excellent thermal performance and excellent electrical conductivity. Ideal for high-performance thermal management.
✓ REACH	Class 4 or* Class 4 Grade B Grade B	

Images for demonstration only

*varies based on plating vendor's certificates of conformance

SOLIDWEDGE™ INSTALLATION

1



Apply Loctite 2760 to #2-56-100° flat head mounting screws (not included)

2

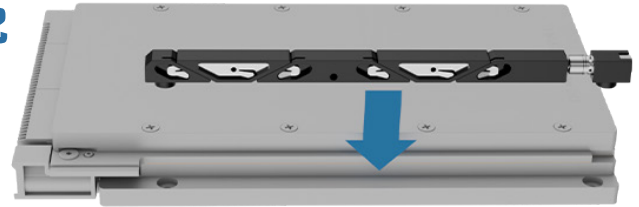

Align SOLIDWEDGE to mounting hole locations

3



Install screws and torque to 2 in-lbs. Ensure mounting screw doesn't hit drive screw.
(reference mounting drawing for max thread engagement)

CHECK INSTALL

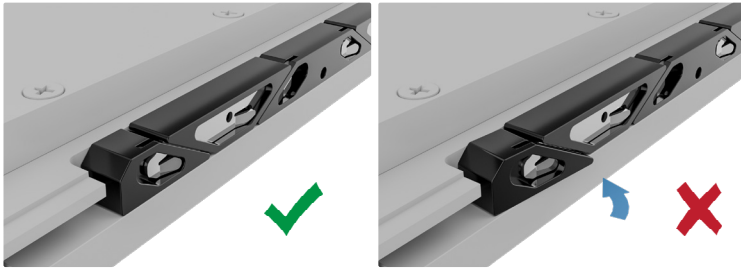

Check alignment on both mounting blocks after torquing and press to straighten if necessary.

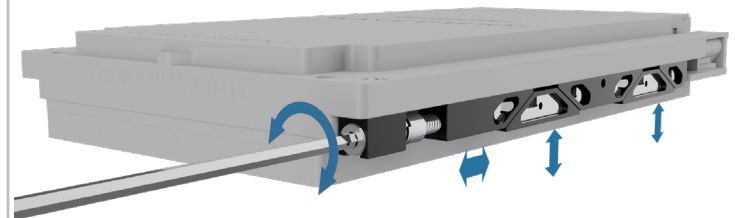

Ensure SOLIDWEDGE is functioning correctly by expanding and contracting with a hex key.

WARNING:



SOLIDWEDGES are not intended to be mounted directly to PCBs. The opposing force of the mounting blocks may result in board damage.