

RIVET DIES

Part Number	Tube Side Rivet Die	Head Side Rivet Die
VFE-80F-06 (0.06" Rivet)	1/16" Tubular Roll Die (ex. CA2005-01)	1/8" Oval Head Die (ex. CA2004-01)
VFE-80F-09 (0.09" Rivet)	3/32" Tubular Roll Die (ex. CA2005-1)	5/32" Oval Head Die (ex. CA2004-1)

EQUIPMENT

Tool	Note
Manual Bench Riveter (ex. HR-141)	Bolt or clamp down
Squeezer Die Adapter x2 (ex. HT-800)	Requires 1 for upper and 1 for lower die

1



Align pawl to heat frame

2

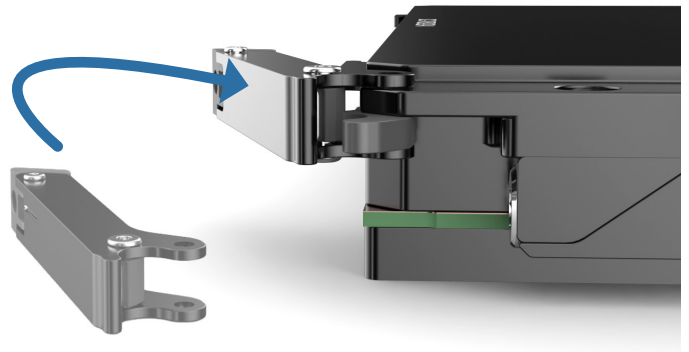

Position ejector body around pawl and heat frame

3

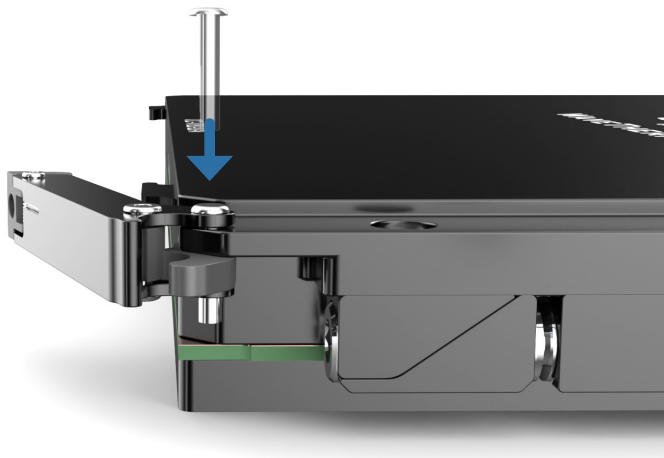

Insert rivet (may be installed either direction)

4

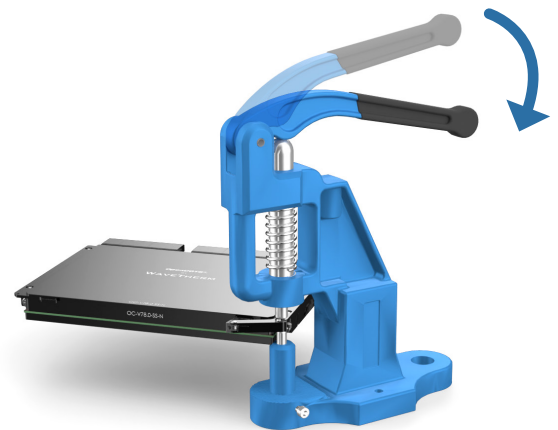

Swage rivet
(ensure tubular roll die is on tube side of rivet)